

öcbah!

CFHC13

Novelty Freezer - 5 Basket



Specifications

Width*	Depth**	Height***	Baskets	Ship Weight	Ship Cube	Cooling Capacity	Electrical
50 3/16" 1275 mm	27 3/8" 695 mm	33 7/8" 860 mm	5	150 lbs 68 kg	46 cu. ft 1.3 m ³	1/6 HP	115V/2.3Amp/60 Hz - Single Phase -NEMA 5-15P, Dedicated Circuit

FREEZER, DISPLAY

Specifications subject to change without notice. Refer to website for most current information.

CFHC13: Designed to enhance the refrigerated storage or display experience to the highest standards of quality and performance.

Refrigeration:

- Adjustable temperature range -18°F to +10°F (-28°C to -12°C).
- Reliable, easily maintained cold wall system is incorporated.
- Thermometer display: external, analog, easily read.
- R-290 natural refrigerant used.
- Quiet compressor, noise level below 50 dB.

Cabinet:

- Exterior – Durable, white zinc coated, baked on enamel steel.
- Interior – Painted white powder coated steel.
- Insulation - Thick, 2.5" foamed in-place, environmentally friendly, polyurethane.
- Removable rubber bumper guards, side grill.
- Heavy Duty 4-way casters.

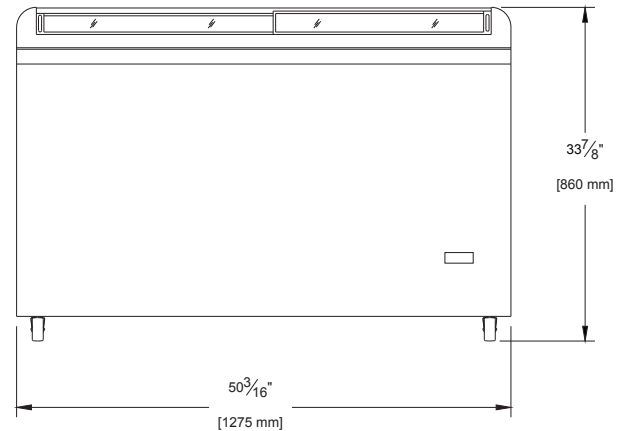

Lid:

- Clear, curved glass sliding lids.
- Easy grip sliding lid handle.
- Lid lock and keys.

Lighting:

- Energy Efficient LED Lighting System for sparkling Illuminated Interior Display, on Switch.

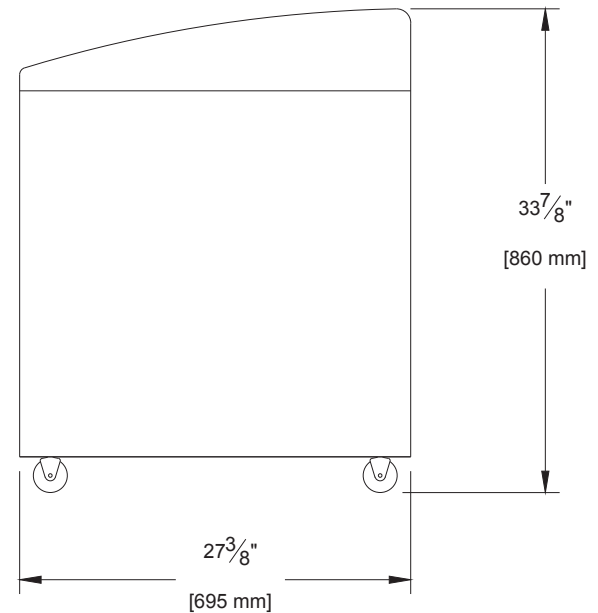

Storage:

- Flat wire baskets with 5 compartments.

Electrical:

- Factory power cord installed for connection to a sole-use (dedicated) 115V/60Hz/1-Phase, 15 Amp circuit.
- Complies with DOE's Energy Efficiency Program.



HABCO MANUFACTURING INC. 501 GORDON BAKER ROAD, TORONTO, ONTARIO, CANADA, M2H 2S6 TollFreeCAN:1-800-387-5398 USA:1-800-448-0244 Fax:416-491-6982 www.habcomfg.com