

öcbah!

CFHC07

Novelty Freezer - 3 Basket



Specifications

Width*	Depth**	Height***	Baskets	Ship Weight	Ship Cube	Cooling Capacity	Electrical
31 11/16" 805 mm	27 3/8" 695 mm	33 7/8" 860 mm	3	125 lbs 57 kg	34 cu. ft 0.96 m ³	1/8 HP	115V/1.7Amp/60 Hz - Single Phase -NEMA 5-15P, Dedicated Circuit

FREEZER,DISPLAY

Specifications subject to change without notice. Refer to website for most current information.

CFHC07: Designed to enhance the refrigerated storage or display experience to the highest standards of quality and performance.

Refrigeration:

- Adjustable temperature range -18°F to +10°F (-28°C to -12°C).
- Reliable, easily maintained cold wall system is incorporated.
- Thermometer display: external, analog, easily read.
- R-290 natural refrigerant used.
- Quiet compressor, noise level below 50 dB.

Cabinet:

- Exterior – Durable, white zinc coated, baked on enamel steel.
- Interior – Painted white powder coated steel.
- Insulation - Thick, 2.5" foamed in-place, environmentally friendly, polyurethane.
- Removable rubber bumper guards, side grill.
- Heavy Duty 4-way casters.

Lid:

- Clear, curved glass sliding lids.
- Easy grip sliding lid handle.
- Lid lock and keys.

Lighting:

- Energy Efficient LED Lighting System for sparkling Illuminated Interior Display, on Switch.

Storage:

- Flat wire baskets with 3 compartments.

Electrical:

- Factory power cord installed for connection to a sole-use (dedicated) 115V/60Hz/1-Phase, 15 Amp circuit.
- Complies with DOE's Energy Efficiency Program.

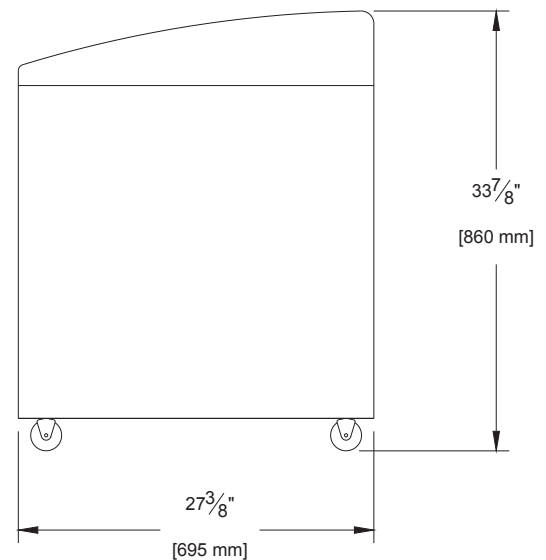
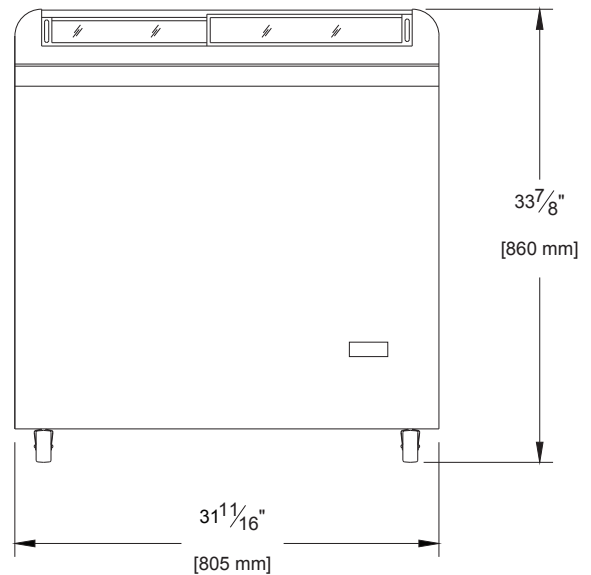

HABCO MANUFACTURING INC. 501 GORDON BAKER ROAD, TORONTO, ONTARIO, CANADA, M2H 2S6 TollFreeCAN:1-800-387-5398 USA:1-800-448-0244 Fax:416-491-6982 www.habcomfg.com

©2017 HABCO Manufacturing Inc. HABCO is a registered trade mark of HABCO Manufacturing Inc. in Canada, USA, U.K. and Germany. HABCO logo design, Built to Perform. Crafted to Last. and CASSETTE are registered trademarks of HABCO Manufacturing Inc. in Canada and U.S.A. Additional trade marks may be employed by HABCO and have been duly noted with respective registration mark or trade mark symbol. DOMESTIC AND INTERNATIONAL PATENTS.