

SE12 RxG

Pharmaceutical Refrigerator

Project Name: _____

Item #: _____ Quantity: _____



Width*	Depth**	Height***	Shelves	Cold Space™	Ship Weight	Ship Cube	Cooling Capacity	Electrical
23 7/8" 607 mm	24" 612 mm	62" 1575 mm	4	12	230 lbs 105 kg	28 cu. ft 0.79 m ³	1/4 HP	115V/2.7 Amp/60 Hz - Single Phase - NEMA 5-15P, Dedicated Circuit

** Add 1" (26mm) for Power Cord. *** Add 3/8" (10mm) for Threaded-In Levelers. Millimeters rounded up.

Premium Features



Cassette® Refrigeration



ProductTemp™



Digitally Controlled

 Finless Free&Clear™
Condenser Coil

 Automatic Stainless Steel
Condensate Control System

 Front Breathing
Refrigeration

Priority Air-Flow



LED Lighting System

 HABCO
Insulated Glass

SE12 RxG: Designed to enhance pharmaceutical storage and display experience to the highest standards of quality and performance.

Refrigeration:

- Self contained Cassette® forced-air refrigeration employs R-134a refrigerant within a sealed capillary tube system.
- Cassette® refrigeration is removable from the front for ease of maintenance. Refrigeration may be exchanged or upgraded without mechanic. Factory preset to hold 36°F to 46°F (2.2°C to 7.7 °C).
- Equipped with Energy Efficient Digital Controller featuring visual/audible product protection alarm.
- Priority, directed air flow provides optimum cooling and energy efficiency within cabinet and exclusively at front of unit for optimized heat exchange ventilation.
- Finless, Free&Clear™ Condenser Coil maximizes air-flow over the compressor, reduces energy consumption and is non-clogging.
- Automatic, stainless steel condensate control system.
- Technologically advanced ProducTemp™ provides exterior product temperature display. Displays to a resolution of 0.1°.
- Quality, self-lubricating and sealed motors with streamlined air-flow provide quieter yet robust refrigeration.

Cabinet:

- Exterior – durable appliance white.
- Interior – NSF approved white aluminum liner with stainless steel floor.
- Ergonomic raised interior floor.
- Space Saving Design – air ventilation exclusively from the front of unit.
- Insulation – cabinet is foamed-in-place with eco-conscious, polyurethane insulation.
- Heavy duty thread-in leveler legs.

Doors:

- Self Closing Swing Doors feature hold-open position, spring back protection and are reversible on-location.
- Magnetic gaskets are single piece bead-mount construction easily removable for cleaning.
- Heat Reflecting HABCO Insulated Safety Glass with black extruded frame.
- Integrated, injection molded pocket handle(s).

Lighting:

- Energy Efficient LED Lighting System for sparkling Illuminated Interior Display, on Switch.

Storage:

- Four (4) white coated shelves 19 1/2"W x 18"D (496mm x 458mm), are NSF approved.
- Heavy duty aluminum shelving pilasters will not peel or chip adjustment of 1/2" (13mm) increments.

Electrical:

- Factory power cord installed for connection to a sole-use (dedicated) 115V/60Hz/1-Phase, 15 Amp circuit.

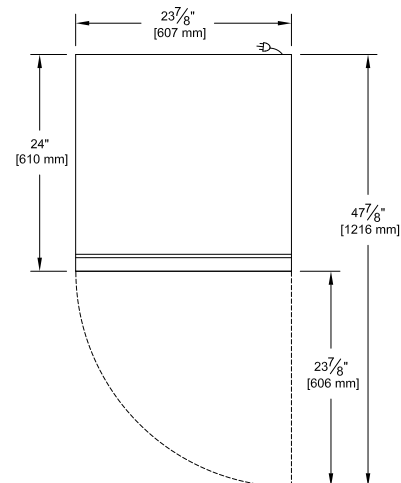
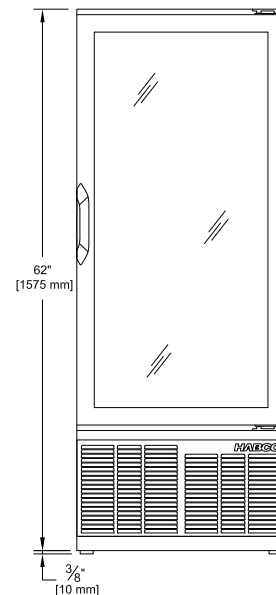

HABCO MANUFACTURING INC. 501 GORDON BAKER ROAD, TORONTO, ONTARIO, CANADA, M2H 2S6
 Toll Free CAN: 1-800-387-5398 USA: 1-800-448-0244 Fax: 416-491-6982 www.habcomfg.com

©2017 HABCO Manufacturing Inc. HABCO is a registered trade mark of HABCO Manufacturing Inc. in Canada, USA, U.K. and Germany. HABCO logo design, Built to Perform. Crafted to Last. and CASSETTE are registered trademarks of HABCO Manufacturing Inc. in Canada and U.S.A. Additional trade marks may be employed by HABCO and have been duly noted with respective registration mark or trade mark symbol. DOMESTIC AND INTERNATIONAL PATENTS.