

HUCR27-1S

Undercounter Refrigerator

Project Name: _____

Item #: _____ Quantity: _____



Width	Depth**	Height***	Shelves	Cold Space™	Ship Weight	Ship Cube	Cooling Capacity	Electrical
27 1/4" 693 mm	31 1/2" 801 mm	34" 864 mm	2	8	206 lbs 93 kg	33 cu. ft. 1 m ³	1/4 HP	115V/2.3 Amp/60 Hz - Single Phase - NEMA 5-15P, Dedicated Circuit

**Add 1/8" (4mm) for fasteners. Millimeters rounded up.

Premium Features



Cassette® Refrigeration



Zero Clearance Design



Finless Free&Clear™
Condenser Coil



Digitally Controlled



Automatic Stainless
Steel Condensate
Control System



Front Breathing
Refrigeration



Priority Air-Flow

HUCR27-1S Designed to enhance refrigerated storage to the highest standards of quality and performance.

Refrigeration:

- Self contained Cassette® forced-air refrigeration employs R-134a refrigerant within a sealed capillary tube system.
- Cassette® refrigeration is bottom-mounted and removable from the front for ease of maintenance. Refrigeration may be exchanged or upgraded without mechanic. Designed to hold 33°F to 38°F (0.5°C to 3.3°C).
- Finless, Free&Clear™ Condenser Coil maximizes air-flow over the compressor, reduces energy consumption and is non-clogging.
- Corrosion resistant coated evaporator coil.
- Automatic, stainless steel condensate control system.
- Equipped with Energy Efficient Digital Controller.
- Quality, self-lubricating and sealed motors with streamlined air-flow provide quieter yet robust refrigeration.

Cabinet:

- Exterior – stainless steel front, top and sides.
- Interior – NSF approved white aluminum liner with stainless steel covered corner floor.
- Ergonomic raised interior floor.
- Space Saving Zero Clearance Design – air ventilation exclusively from the front of unit.
- Insulation – cabinet and solid doors are foamed-in-place with eco-conscious, polyurethane insulation.
- Equipped with 1/2" (13mm) casters.

Doors:

- Self-Closing Swing Doors feature hold-open position, and spring-back protection.
- Magnetic gaskets are single piece bead-mount construction easily removable for cleaning.
- Large, recessed door handle(s).

Storage:

- Two (2) white coated shelves 22 5/8"W x 25"D (575mm x 635mm), are NSF approved.
- Heavy duty aluminum shelving pilasters will not peel or chip adjustment of 1/2" (13mm) increments.
- Interior accepts typical 18" x 26" (458mm x 661mm) sheet pans.
- NSF-7 compliant for storage and display of open food product.

Electrical:

- Factory power cord installed for connection to a sole-use (dedicated) 115V/60Hz/1-Phase, 15 Amp circuit.

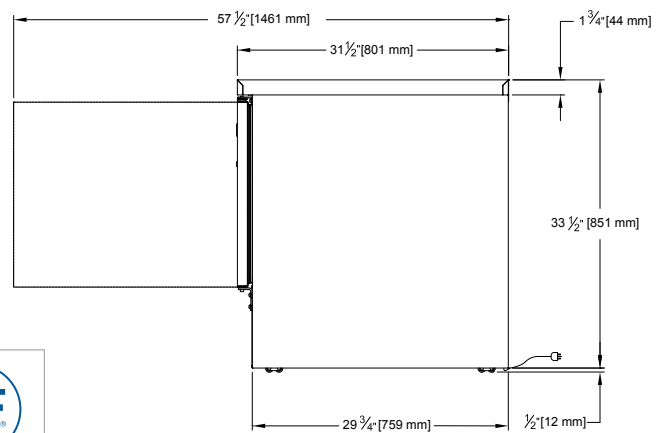
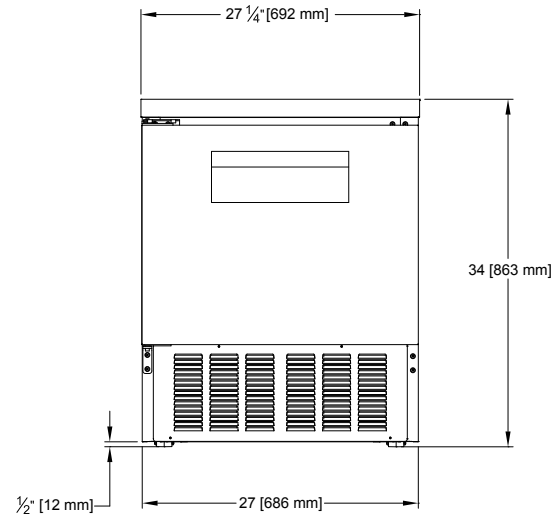

Special Inspection by CSA International



HABCO MANUFACTURING INC. 501 GORDON BAKER ROAD, TORONTO, ONTARIO, CANADA, M2H 2S6

Toll Free CAN: 1-800-387-5398 USA: 1-800-448-0244 Fax: 416-491-6982 www.habcomfg.com