

# HFP27-8-1S

## Food Prep Table

Project Name: \_\_\_\_\_

Item #: \_\_\_\_\_ Quantity: \_\_\_\_\_



Width*	Depth**	Height***	Shelves	Cold Space™	Ship Weight	Ship Cube	Cooling Capacity	Electrical
27 1/4" 693 mm	31 1/2" 801 mm	42 1/2" 1080 mm	2	6	206 lbs 93 kg	33 cu. ft 1 m <sup>3</sup>	1/4 HP	115V/10 Amp/60 Hz - Single Phase - NEMA 5-15P, Dedicated Circuit

\* Add 1/4" (7mm) for fasteners. \*\*Add 1/8" (4mm) for fasteners. \*\*\*Includes Hood, Casters and Lid closed. Add 6" (127mm) for Lid open. Millimeters rounded up.

### Premium Features



Cassette® Refrigeration



Whisper Air-Over-Pan™



Zero Clearance Design

 Removeable  
Pan Catcher™

 Finless Free&Clear™  
Condenser Coil

Digitally Controlled

 Automatic Stainless  
Steel Condensate  
Control System

 Front Breathing  
Refrigeration

Priority Air-Flow

## HFP27-8-1S: Designed to enhance the food preparation experience, with attention to detail and innovation.

### Refrigeration:

- Self contained Cassette® forced-air refrigeration employs R-134a refrigerant within a sealed capillary tube system
- Cassette® refrigeration is bottom-mounted and removable from the front for ease of maintenance. Refrigeration may be exchanged without mechanic. Designed to hold 33°F to 38°F (0.5°C to 3.3°C).
- Priority, directed air flow provides optimum cooling and energy efficiency within cabinet, over food pans and exclusively at front of unit for optimized heat exchange ventilation.
- Cold, Whisper-Air-Over-Pan™ design minimizes dehydration of food during serving.
- Finless, Free&Clear™ Condenser Coil maximizes air-flow over the compressor, reduces energy consumption and is non-clogging.
- Corrosion resistant coated evaporator coil.
- Automatic, stainless steel condensate control system.
- Equipped with Energy Efficient Digital Controller
- Quality, self-lubricating and sealed motors with streamlined air-flow provide quieter yet robust refrigeration.



### Cabinet:

- Exterior - stainless steel front, top and sides
- Interior - NSF approved white aluminum liner with stainless steel covered corner floor
- Ergonomic raised interior floor.
- Space Saving Zero Clearance Design - air ventilation exclusively from the front of the unit
- Exclusive Pan Catcher™ is removable through pan section opening without tools for optimum sanitation. Features easy clean-out corners for quick spill clean-up.
- Insulation - Cabinet and solid doors are foamed-in-place with eco-conscious, polyurethane insulation.
- Equipped with 2 1/2" (635mm) casters, Two (2) with locks.

### Doors:

- Self-Closing Swing Door(s) feature hold-open position, and spring-back protection.
- Foam insulated hood and lid removes for cleaning.
- Magnetic gaskets are single piece bead-mount construction easily removable for cleaning.
- Large, recessed door handle(s)

### Storage:

- Two (2) white coated shelves 22 5/8" W x 25"D (575mm x 635mm), are NSF approved.
- Heavy duty aluminum shelving pilasters will not peel or chip adjustment of 1/2" (13mm) increments.
- Durable cutting surface is 10 1/2" (292mm) deep, 1/2" (13mm) thick, full length and removable. Manufactured from high-density, NSF approved white polyethylene.
- Equipped with Six (6) - 1/6<sup>th</sup> and Two (2) 1/9<sup>th</sup> NSF approved polycarbonate food pans. Will accommodate 6" (153mm) deep food pans supplied by others.
- Interior accepts typical 18" x 26" (458mm x 661mm) sheet pans.
- Pan section designed to facilitate various pan sizes and configurations. Additional pan dividers available.
- NSF-7 compliant for storage and display of open food product.

### Electrical:

- Factory power cord installed for connection to a sole-use (dedicated) 115V/60Hz/1-Phase, 15 Amp circuit.

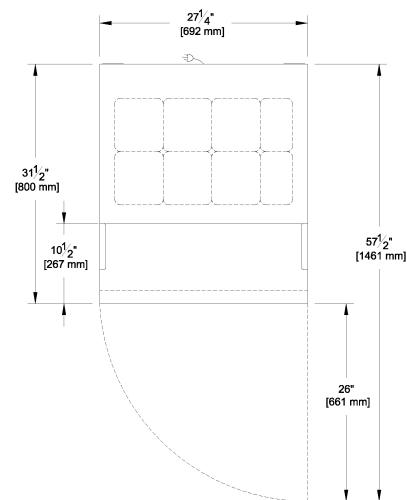
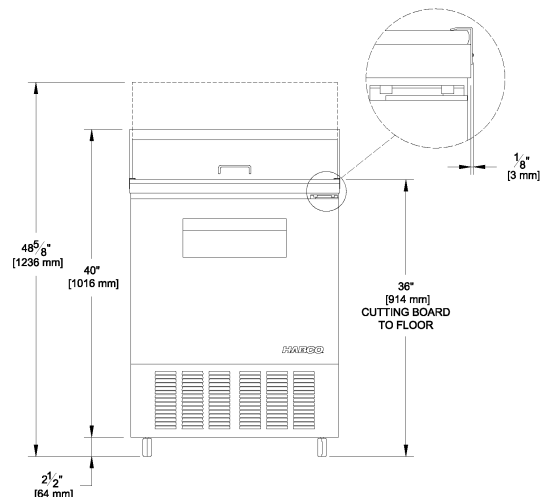

HABCO MANUFACTURING INC. 501 GORDON BAKER ROAD, TORONTO, ONTARIO, CANADA, M2H 2S6  
 Toll Free CAN: 1-800-387-5398 USA: 1-800-448-0244 Fax: 416-491-6982 www.habcomfg.com

©2018 HABCO Manufacturing Inc. HABCO is a registered trade mark of HABCO Manufacturing Inc. in Canada, USA, U.K. and Germany. HABCO logo design, Built to Perform. Crafted to Last. and CASSETTE are registered trademarks of HABCO Manufacturing Inc. in Canada and U.S.A. Additional trade marks may be employed by HABCO and have been duly noted with respective registration mark or trade mark symbol. DOMESTIC AND INTERNATIONAL PATENTS.

