

# SE24M

*Refrigerator, Merchandiser*

Project Name: \_\_\_\_\_

Item #: \_\_\_\_\_ Quantity: \_\_\_\_\_



Width*	Depth**	Height***	Shelves	Cold Space™	Ship Weight	Ship Cube	Cooling Capacity	Electrical
23 7/8" 607 mm	31" 788 mm	78" 1982 mm	3	24	256 lbs 116 kg	41 cu. ft 1.16 m <sup>3</sup>	1/4 HP	115V/2.7 Amp/60 Hz - Single Phase - NEMA 5-15P, Dedicated Circuit

\*\* Add 1 1/2" (39mm) for Handle and 1" (26mm) for Power Cord – O/A 2 1/2" (64mm). \*\*\* Add 3/8" (10mm) for Threaded-In Levelers. Millimeters rounded up. Shipped less Graphics. Custom Graphics Optional.

## Premium Features



Cassette® Refrigeration



Finless Free&Clear™  
Condenser Coil



LED Lighting System



Automatic Stainless Steel  
Condensate Control System



Front Breathing  
Refrigeration



Priority Air-Flow



HABCO  
Insulated Glass

**SE24M:** Designed to optimize merchandising experience to the highest standards of quality and performance.

**Refrigeration:**

- Self contained Cassette® forced-air refrigeration employs R-134a refrigerant within a sealed capillary tube system.
- Cassette® refrigeration is bottom-mounted and removable from the front for ease of maintenance. Refrigeration may be exchanged or upgraded without mechanic. Designed to hold 33°F to 38°F (0.5°C to 3.3°C).
- Priority, directed air flow provides optimum cooling and energy efficiency within cabinet and exclusively at front of unit for optimized heat exchange ventilation.
- Finless, Free&Clear™ Condenser Coil maximizes air-flow over the compressor, reduces energy consumption and is non-clogging.
- Corrosion resistant coated evaporator coil.
- Automatic, stainless steel condensate control system.
- Quality, self-lubricating and sealed motors with streamlined air-flow provide quieter yet robust refrigeration.

**Cabinet:**

- Exterior – durable appliance white.
- Interior – NSF approved white aluminum liner with stainless steel covered corner floor.
- Ergonomic raised interior floor.
- Space Saving Design – air ventilation exclusively from the front of unit.
- Insulation – cabinet is foamed-in-place with eco-conscious, polyurethane insulation.
- Heavy duty thread-in leveler legs.

**Doors:**

- Self Closing Swing Doors feature hold-open position, spring back protection and are reversible on-location.
- Magnetic gaskets are single piece bead-mount construction easily removable for cleaning.
- Heat Reflecting HABCO Insulated Safety Glass with black extruded frame.
- Durable, external door handle(s).

**Lighting:**

- Energy Efficient LED Lighting System for crisp Illuminated Signage and Interior Display, on Switch.

**Storage:**

- Three (3) white coated shelves 19 1/2"W x 22 3/4"D (496mm x 578mm) are NSF approved.
- Heavy duty aluminum shelving pilasters will not peel or chip adjustment of 1/2" (13mm) increments.
- Interior accepts typical 18" x 26" (458mm x 661mm) sheet pans.
- NSF-7 compliant for storage and display of open food product.

**Electrical:**

- Factory power cord installed for connection to a sole-use (dedicated) 115V/60Hz/1-Phase, 15 Amp circuit.

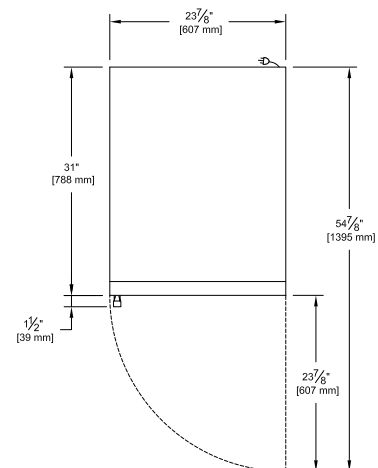
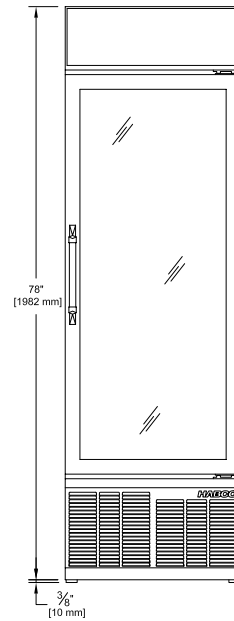

HABCO MANUFACTURING INC. 501 GORDON BAKER ROAD, TORONTO, ONTARIO, CANADA, M2H 2S6  
 Toll Free CAN: 1-800-387-5398 USA: 1-800-448-0244 Fax: 416-491-6982 www.habcomfg.com