

# SE18M

Refrigerator, Merchandiser

Project Name: \_\_\_\_\_

Item #: \_\_\_\_\_ Quantity: \_\_\_\_\_



Width*	Depth**	Height***	Shelves	Cold Space™	Ship Weight	Ship Cube	Cooling Capacity	Electrical
23 7/8" 607 mm	24" 610 mm	78" 1982 mm	3	17.2	218 lbs 99 kg	35 cu. ft 0.99 m <sup>3</sup>	1/4 HP	115V/2.7 Amp/60 Hz - Single Phase - NEMA 5-15P, Dedicated Circuit

\*\* Add 1 1/2" (39mm) for Handle and 1" (26mm) for Power Cord – O/A 2 1/2" (64mm). \*\*\* Add 3/8" (10mm) for Threaded-In Levelers. Millimeters rounded up. Shipped less Graphics. Custom Graphics Optional.

## Premium Features



Cassette® Refrigeration



Finless Free&Clear™  
Condenser Coil



LED Lighting System



Automatic Stainless Steel  
Condensate Control System



Front Breathing  
Refrigeration



Priority Air-Flow



HABCO  
Insulated Glass

**SE18M:** Designed to optimize merchandising experience to the highest standards of quality and performance.

**Refrigeration:**

- Self contained Cassette® forced-air refrigeration employs R-134a refrigerant within a sealed capillary tube system.
- Cassette® refrigeration is bottom-mounted and removable from the front for ease of maintenance. Refrigeration may be exchanged or upgraded without mechanic. Designed to hold 33°F to 38°F (0.5°C to 3.3°C).
- Priority, directed air flow provides optimum cooling and energy efficiency within cabinet and exclusively at front of unit for optimized heat exchange ventilation.
- Finless, Free&Clear™ Condenser Coil maximizes air-flow over the compressor, reduces energy consumption and is non-clogging.
- Corrosion resistant coated evaporator coil.
- Automatic, stainless steel condensate control system.
- Quality, self-lubricating and sealed motors with streamlined air-flow provide quieter yet robust refrigeration.

**Cabinet:**

- Exterior – durable appliance white.
- Interior – NSF approved white aluminum liner with stainless steel coved corner floor.
- Ergonomic raised interior floor.
- Space Saving Design – air ventilation exclusively from the front of unit.
- Insulation – cabinet is foamed-in-place with eco-conscious, polyurethane insulation.
- Heavy duty thread-in leveler legs.

**Doors:**

- Self Closing Swing Doors feature hold-open position, spring back protection and are reversible on-location.
- Magnetic gaskets are single piece bead-mount construction easily removable for cleaning.
- Heat Reflecting HABCO Insulated Safety Glass with black extruded frame.
- Durable, external door handle(s).

**Lighting:**

- Energy Efficient LED Lighting System for crisp Illuminated Signage and Interior Display, on Switch.

**Storage:**

- Three (3) white coated shelves 19 1/2"W x 18"D (496mm x 458mm) are NSF approved.
- Heavy duty aluminum shelving pilasters will not peel or chip adjustment of 1/2" (13mm) increments.
- NSF-7 compliant for storage and display of open food product.

**Electrical:**

- Factory power cord installed for connection to a sole-use (dedicated) 115V/60Hz/1-Phase, 15 Amp circuit.

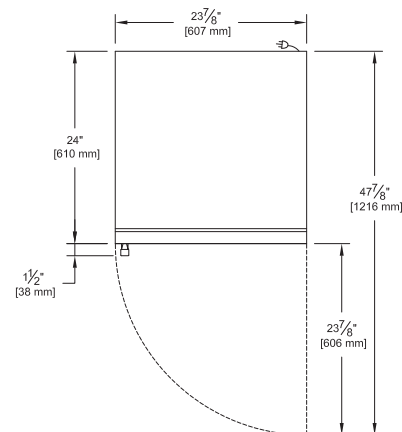
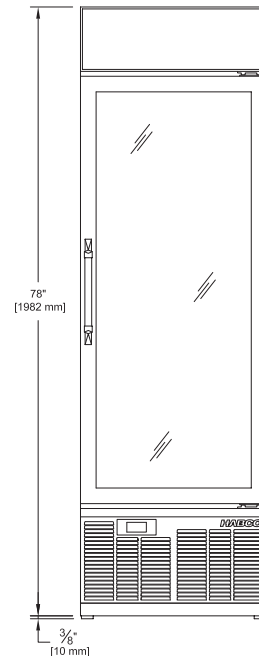

HABCO MANUFACTURING INC. 501 GORDON BAKER ROAD, TORONTO, ONTARIO, CANADA, M2H 2S6  
 Toll Free CAN: 1-800-387-5398 USA: 1-800-448-0244 Fax: 416-491-6982 www.habcomfg.com

©2017 HABCO Manufacturing Inc. HABCO is a registered trade mark of HABCO Manufacturing Inc. in Canada, USA, U.K. and Germany. HABCO logo design, Built to Perform. Crafted to Last. and CASSETTE are registered trademark of HABCO Manufacturing Inc. in Canada and U.S.A. Additional trade marks may be employed by HABCO and have been duly noted with respective registration mark or trade mark symbol. DOMESTIC AND INTERNATIONAL PATENTS.