

SF24SX

Stainless Xterior™ Freezer

Project Name: _____

Item #: _____ Quantity: _____



Width*	Depth**	Height***	Shelves	Cold Space™	Ship Weight	Ship Cube	Cooling Capacity	Electrical
23 7/8" 607 mm	31" 788 mm	78" 1982 mm	3	24	275 lbs 125 kg	41 cu. ft 1.16 m ³	1/3 HP	115V/6.2 Amp/60 Hz - Single Phase - NEMA 5-15P, Dedicated Circuit

*** Add 3/8" (10mm) for Threaded-In Levelers. Millimeters rounded up.

Premium Features



Finless Free&Clear™
Condenser Coil



ProductTemp™



Digitally Controlled



Automatic Stainless Steel
Condensate Control System



Priority Air-Flow

SF24SX: Designed to enhance the refrigerated storage or display experience to the highest standards of quality and performance.

Refrigeration:

- Traditional non-removable, split forced-air refrigeration system employs R-404a refrigerant within a sealed capillary tube system.
- Condensing unit is bottom-mounted and can be accessed from the front for ease of maintenance.
- Priority, directed air flow provides optimum cooling and energy efficiency through front of unit for optimized heat exchange ventilation.
- Finless, Free&Clear™ Condenser Coil maximizes air-flow over the compressor, reduces energy consumption and is non-clogging.
- Corrosion resistant coated evaporator coil.
- Automatic, stainless steel condensate control system.
- Equipped with Energy Efficient Digital Controller featuring visual/audible product protection alarm. Freezers factory preset for -23.3°C (-10°F).
- Technologically advanced ProcuTemp™ provides exterior product temperature display. Displays to a resolution within 1°.
- Energy-Saving, Time-Initiated, Temperature-Terminated Defrost System with Evaporator Fan Motor Delay during Defrost and Fan Motor Interrupt on Door Opening. Features Manual Defrost Override.
- Low Energy Cabinet Mullion Heater prevents frosting.
- Quality, self-lubricating and sealed motors with streamlined air-flow provide quieter yet robust refrigeration.
- Equipped with Digital Thermometer.

Cabinet:

- Exterior – stainless steel front and sides.
- Interior – NSF approved white aluminum liner with stainless steel coved corner floor.
- Ergonomic raised interior floor.
- Insulation – cabinet and solid doors are foamed-in-place with eco-conscious, polyurethane insulation.
- Heavy duty thread-in leveler legs.

Doors:

- Stainless steel front with white aluminum interior liner and large grip, recessed handle(s).
- Self-Closing Swing Door features hold-open position, spring-back protection, and door lock, both reversible on-location.
- Magnetic gaskets are single piece bead-mount construction easily removable for cleaning.
- Door lock included is reversible on-location.

Lighting:

- Auto-Actuated Interior Lighting.

Storage:

- Three (3) white coated shelves 19 1/2"W x 22 3/4"D (496mm x 578mm) are NSF approved.
- Heavy duty aluminum shelving pilasters will not peel or chip adjustment of 1/2" (13mm) increments.
- Interior accepts typical 18" x 26" (458mm x 661mm) sheet pans.
- NSF-7 compliant for storage and display of open food product.

Electrical:

- Factory power cord installed for connection to a sole-use (dedicated) 115V/60Hz/1-Phase, 15 Amp circuit.

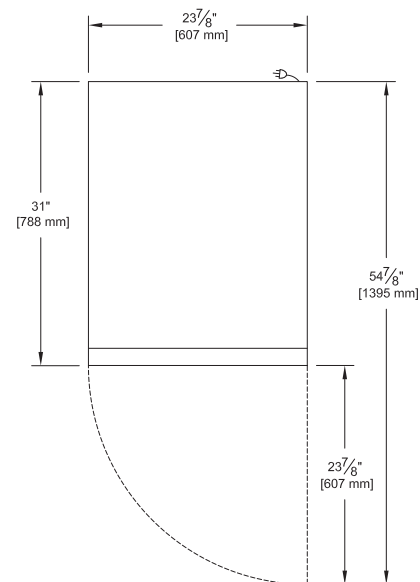
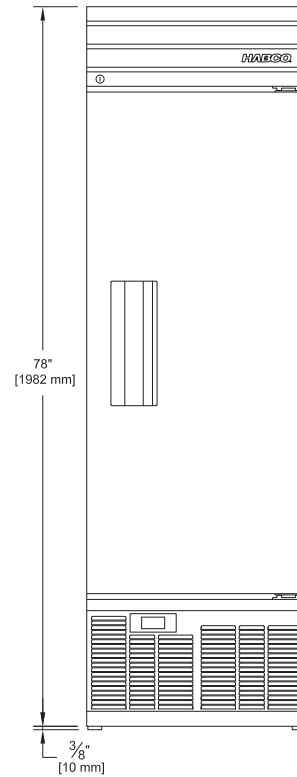

<p>Special Inspection by CSA International</p>			
---	--	--	--

HABCO MANUFACTURING INC. 501 GORDON BAKER ROAD, TORONTO, ONTARIO, CANADA, M2H 2S6
 Toll Free CAN: 1-800-387-5398 USA: 1-800-448-0244 Fax: 416-491-6982 www.habcomfg.com

©2017 HABCO Manufacturing Inc. HABCO is a registered trade mark of HABCO Manufacturing Inc. in Canada, USA, U.K. and Germany. HABCO logo design, Built to Perform. Crafted to Last. and CASSETTE are registered trademark of HABCO Manufacturing Inc. in Canada and U.S.A. Additional trade marks may be employed by HABCO and have been duly noted with respective registration mark or trade mark symbol. DOMESTIC AND INTERNATIONAL PATENTS.