

ESM28

Cold Space Merchandiser®

Project Name: _____

Item #: _____ Quantity: _____



Width*	Depth**	Height***	Shelves	Cold Space™	Ship Weight	Ship Cube	Cooling Capacity	Electrical
30 1/2" 775 mm	31" 788 mm	78" 1982 mm	5	28	348 lbs 158 kg	49 cu. ft 1.39 m ³	1/3 HP	115V/4.5 Amp/60 Hz - Single Phase - NEMA 5-15P, Dedicated Circuit

** Add 1" (26mm) for Power Cord. *** Add 3/8" (10mm) for Threaded-In Levelers. Millimeters rounded up.

Shipped less Graphics. Custom Graphics Optional.

Flat Shelf 20 oz /600ml		Gravity GlideSet™ 20 oz /600ml		Trailerload Quantity (53')
Packout	Facings	Packout	Facings	
315	9	280	8	57

Premium Features



Cassette® Refrigeration

 Finless Free&Clear™
Condenser Coil

LED Lighting System

 Automatic Stainless Steel
Condensate Control System

 Front Breathing
Refrigeration

Priority Air-Flow

 HABCO
Insulated Glass

ESM28: Designed to optimize merchandising experience to the highest standards of quality and performance.

Refrigeration:

- Self contained Cassette® forced-air refrigeration employs R-134a refrigerant within a sealed capillary tube system.
- Cassette® refrigeration is bottom-mounted and removable from the front for ease of maintenance. Refrigeration may be exchanged or upgraded without mechanic. Designed to hold 33°F to 38°F (0.5°C to 3.3°C).
- Priority, directed air flow provides optimum cooling and energy efficiency within cabinet and exclusively at front of unit for optimized heat exchange ventilation.
- Finless, Free&Clear™ Condenser Coil maximizes air-flow over the compressor, reduces energy consumption and is non-clogging.
- Automatic, stainless steel condensate control system.
- Quality, self-lubricating and sealed motors with streamlined air-flow provide quieter yet robust refrigeration.

Cabinet:

- Exterior – durable textured black.
- Interior – NSF approved white aluminum liner with stainless steel floor.
- Ergonomic raised interior floor.
- Space Saving Design – air ventilation exclusively from the front of unit.
- Insulation – cabinet is foamed-in-place with eco-conscious, polyurethane insulation.
- Heavy duty thread-in leveler legs.

Doors:

- Self-Closing Swing Door features hold-open position and spring-back protection, reversible on-location.
- Magnetic gaskets are single piece bead-mount construction easily removable for cleaning.
- Heat Reflecting HABCO Insulated Safety Glass with black extruded frame.
- Integrated, injection molded pocket handle(s).

Lighting:

- Energy Efficient LED Lighting System for crisp illuminated Signage and Interior Display, on Switch.

Storage:

- Five (5) white coated shelves 26 1/4"W x 22"D (667mm x 559mm), are NSF approved.
- Heavy duty aluminum shelving pilasters will not peel or chip adjustment of 1/2" (13mm) increments.
- NSF-7 compliant for storage or display of pre-packaged aseptic product.

Electrical:

- Factory power cord installed for connection to a sole-use (dedicated) 115V/60Hz/1-Phase, 15 Amp circuit.

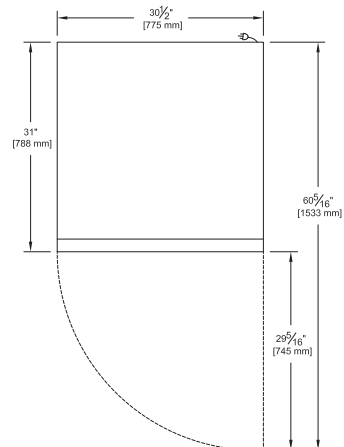
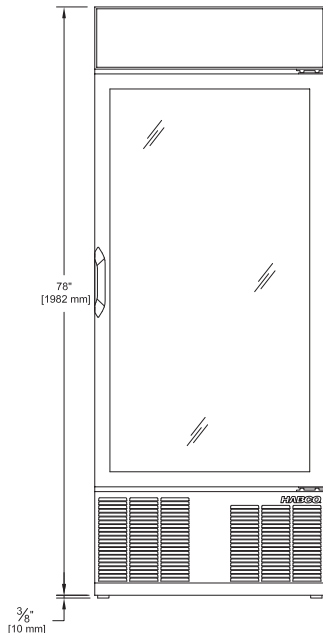

HABCO MANUFACTURING INC. 501 GORDON BAKER ROAD, TORONTO, ONTARIO, CANADA, M2H 2S6
 Toll Free CAN: 1-800-387-5398 USA: 1-800-448-0244 Fax: 416-491-6982 www.habcomfg.com